

Aftermarket, Service & Repair

- ✓ Uptime Assurance
- ✓ Upgrades & Retrofits
- ✓ Rerates
- ✓ Overhaul & Repairs
- ✓ Exchange Gearboxes
- ✓ Genuine Parts
- ✓ Applications Review

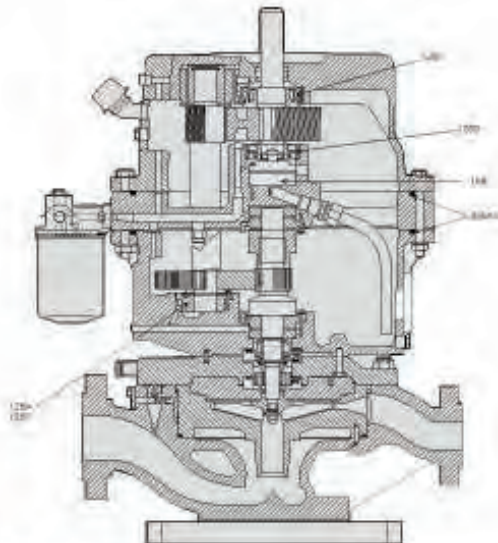

Optimizing the customer experience by extending the life of your Sundyne compressors and pumps!

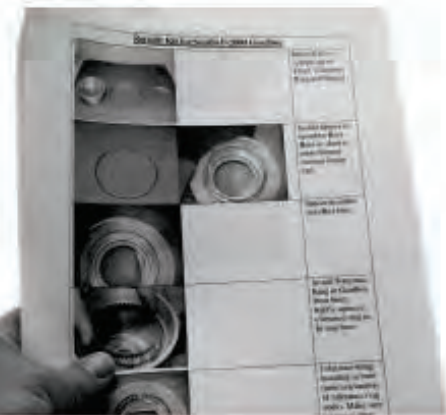

Global coverage, local support

Our global network ensures fast local service and support.



Authorized Service Overview

Sundyne is much more than just a manufacturer of high quality compressors and pumps. We back our products with a full range of aftermarket support services, extending the value of our highly engineered fluid handling products.

Our service strategy is centered around delivering a trouble-free customer experience. Put simply: our service team is here to help you protect your equipment investment.

We are capable of executing virtually any support service you require, in house or in the field and around the world.

MAP LEGEND

- Authorized Service Centers
- ▲ Manufacturing Sites
- Channel Partners

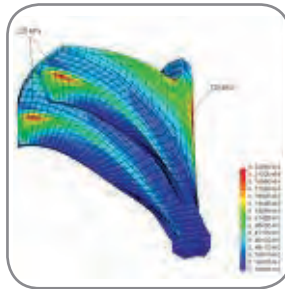
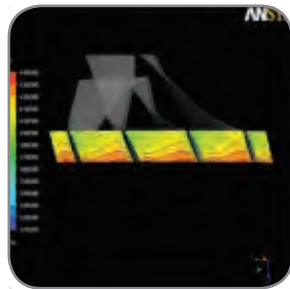

State-of-the-art technology for equipment testing. (ie. Vibration Monitoring & Analysis)

Sundyne delivers significant benefits to our customers and service network with the utilization of various advanced technical and structural analysis techniques.

Contact your local
Authorized Service Center.
Visit: www.sundyne.com
to locate the ASC nearest you.





Customers learn how to effectively operate and maintain Sundyne equipment at classes held throughout the year in the US and France.



Sundyne support services maximize your process and plant uptime.

Whether you are utilizing Sundyne products in the United States, Brazil or Saudi Arabia, you will always have access to the support and maintenance services you require.

Our factory and field service programs are the ideal solution for maintaining and improving your Sundyne compressors and pumps.

Increasing the overall reliability and life of your equipment is our number one goal.

Support Services Include:

- **Engineering expertise**
- **Overhaul and repair**
- **Performance testing**
- **Precision balancing**
- **Vibration analysis**
- **Failure analysis**
- **Machine history**
- **Specialized training**
- **Preventive maintenance**
- **Specialized tooling**
- **Sundyne genuine parts**
- **Trouble-shooting**

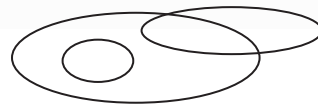

Our Product Support Guarantee



Sundryne has a proud heritage of pioneering innovation and advanced engineering excellence. We don't just manufacture some of the most reliable compressors and pumps available on the market; we engineer them to specifically suit your application, configuring the Best Efficiency Point for your operating conditions and assisting with the commissioning process.

We've been delivering successful results to some of the largest names in the industry for more than 50 years.

Training For Operational Excellence



Maintenance & Operations Training

Our customers and channel partners are both provided with a full range of maintenance and operations training programs. We strive to ensure that you are ready to handle all aspects of commissioning and provide you with long-term successful operation of your Sundryne compressors and pumps. Register for classes throughout the year at www.sundryne.com.

Commissioning Services

Proper pre-commissioning and startup is essential to ensure optimum performance and MTBPM of your Sundryne compressors and pumps. Our network of Authorized Service Centers and international manufacturing centers are available to provide you with the support needed during this critical phase.

Sundryne is ready to assist with installation, controls and auxiliaries. Our goal is to maximize the level of operational success and longevity of your investment. Our site review program is designed to identify any potential problems that could adversely affect your equipment.



Great care and safety is practiced on each and every installation or maintenance operation.





When you see the Sundyne logo, you can be sure that it's a Sundyne Genuine Part



Our logo stands as a symbol of our dedication to quality and customer service. When you purchase Sundyne Genuine Parts, there's a company that stands behind every component that leaves our extensive network of Authorized Service Centers... and when it comes to extending the service life of your Sundyne compressors or pumps, that can mean a world of difference.

Aside from superior quality, our replacement parts and service assistance offer something not available through replicators and imitators: peace of mind.

Our Sundyne Genuine Parts are the clear choice, offering:

- **High Quality Standards** – Sundyne parts are engineered and manufactured to rigorous standards, then checked for dimensional integrity and accurate installation fit.
- **24-Hour Support** – We provide factory-based customer service and technical field support 24 hours a day, 7 days a week so that you have access to the expertise you require when you need it most.
- **Repair Specialists** – Our extensive network of Authorized Service Centers employs best practices and Sundyne Genuine Parts to return your equipment to like-new condition.
- **Warranty Protection** – Sundyne Genuine Parts and Service are fully warranted.

We provide spares recommendations for all equipment for commissioning and ongoing operational use.



Genuine Parts Built To Order



The Sundyne spare parts account team is standing by to facilitate streamlined parts procurement.

ENHANCED MTBPM!

Nothing is forever, including your system's optimal efficiency...

During the course of a compressor or pump's lifecycle, the process or system environment that unit resides within will experience changes in requirements due to changes in operational demands. Enhanced reliability standards, modifications to your process, safety concerns and even new industry compliance standards will cause a chain reaction of events that ultimately decreases your system's efficiency. This will lead to increased power consumption, suction or discharge recirculation, temperature fluctuations and even cavitation – process inefficiencies that will dramatically affect your bottom line.

Our service offerings will return your Sundyne compressors and pumps back to their best efficiency point (BEP).

Why upgrade your compressor or pump?

- Improved reliability
- Reduced maintenance costs
- Reduced energy costs
- Improved efficiency
- Increased production
- Improved environmental safety

When you upgrade, you will expect:

- A revised expected performance curve
- A revised specification sheet
- An updated bill of materials for your records
- A re-optimized system that returns you to your Best Efficiency Point
- No change to your existing process piping or installation

Your Authorized Service Center will discuss...

FACTORY	FIELD (ASC)	(Contact the Authorized Service Center nearest you for comprehensive service solutions.)
✓	✓	Where on the curve your equipment should be operated to ensure proper reliability.
✓	✓	Which conditions outside of min-flow or max-flow specifications will place your equipment at risk.
✓	✓	When a re-rate is needed as a result of operational change.
✓	✓	Which interchangeable diffusers, impellers and speeds allow for re-rate capability.
✓	✓	Various metallurgy recommendations that will help you improve mtbpm.
✓	✓	Equipment testing to certify performance.

Gearbox Upgrades

Upgrading your Sundyne compressor or pump gearbox is a quick and easy way to improve overall reliability and longevity of the unit. Upgrade anytime...even before your next scheduled preventive maintenance! Get the enhanced output and reliability that only Sundyne will deliver, all by simply swapping your old gearbox out for a new one.



*Don't delay.
Get up-to-speed
with the most
recent gearbox
upgrades!*

Contact an Authorized Service Center today!

Our newly redesigned Sundyne gearboxes provide a host of operational benefits, including:

- **Improved reliability and extended operating life**
- **Reduced noise and vibration level**
- **Gearbox life has been increased through continuous improvement to seal technology**
- **Higher thrust capabilities, as well as improved lubrication and filtration**
- **Reduced foaming for easy and accurate oil level indication during operation**

Avoid costly downtime and gain a lifetime of reliability by taking advantage of our **SUNDYNE GEARBOX EXCHANGE** program.

Replace your aging gearbox assembly at a substantial cost savings, receiving a replacement gearbox and a significant return credit in exchange for your existing hardware.

The upgraded gearbox assemblies are interchangeable and allow for quick and easy installation.

The gearbox is warranted for either 12 months from start-up or 18 months from date of shipment, whichever occurs first.

Sundyne also offers a **SUNFLO SHAFT ASSEMBLY EXCHANGE** program, providing an excellent way for you to keep your Sunflo pumps running reliably. Under this program, we provide re-built shaft assemblies to customers who do not wish to purchase brand new assemblies. We simply send you the re-built assembly and you return the old one to our factory, resulting in reduced downtime, minimized maintenance costs and maximized output



COMPRESSORS

PUMPS

GENUINE PARTS

SERVICE

Sundyne Headquarters:

Sundyne, LLC
14845 West 64th Avenue
Arvada, Colorado 80007
USA
1-866-Sundyne
Phone: 1.303.425.0800
Fax: 1.303.425.0896
www.sundyne.com

Sundyne China:
Building 1, No. 879 Shen Fu Road
XinZhuang Industrial Zone
Min Hang District
Shanghai, China 201108
Phone: +8621 5055 5005
Fax: +8621 5442 5265

Sundyne France:
Sundyne International S.A.
13-15, Boulevard Eiffel - B.P. 30
21604 Longvic Cedex
France
Phone: +33 380 38 33 00
Fax: +33 380 38 33 66

Sundyne Spain:
Sundyne Marelli Bombas, S.R.L.
Ctra. Madrid-Toledo, Km.30.8
45200 Illescas
Toledo, Spain
Phone: +34 925 53 45 00
Fax: +34 925 51 16 00

Sundyne United Kingdom:
Sundyne HMDKontro Sealless Pumps, Ltd.
Marshall Road
Hampden Park Industrial Estate
Eastbourne East Sussex, BN22 9AN
United Kingdom
Phone: +44 1323 452000
Fax: +44 1323 503369
Email: info@hmdkontro.com

Worldwide Sales Headquarters
Unit 2 Harvington Business Park
Hampden Park Industrial Estate
Brampton Road
Eastbourne East Sussex, BN22 9BN
United Kingdom
Phone: +44(0) 1323 452125

All information provided is
subject to change without notice.
© 2013 Sundyne, LLC
All Rights Reserved. Other logos
and trade names are property of
their respective owners.

Aftermarket, Service & Repair Brochure
081513: A4 (v.2) POD



Kinder-Janes Engineers Ltd
Porters Wood, St. Albans
AL3 6HU United Kingdom
Phone +44 (0) 1727 844 441
www.kinder-janes.co.uk

